

**BERNINA<sup>+</sup>**

***BERNINA 950 Industrial –  
the universal sewing machine  
for industrial and professional use***

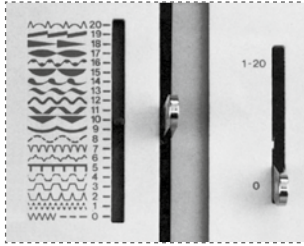

**950**  
**BERNINA<sup>+</sup>**



### Utility and decorative stitches

Simply adjust the lever to select the stitch of your choice – even while sewing.

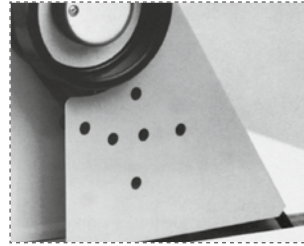

### Belt shield on hand wheel

The belt shield prevents contact with the running belt, thus ensuring you a high degree of safety when sewing.

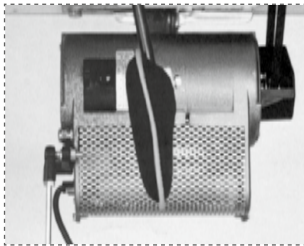

### Integrated presser foot lifter

Knee-operated lifter for raising and lowering the presser foot – with an up stop position.

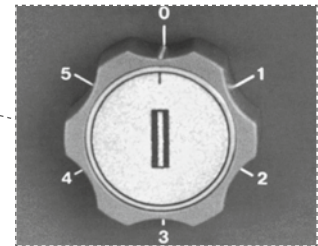
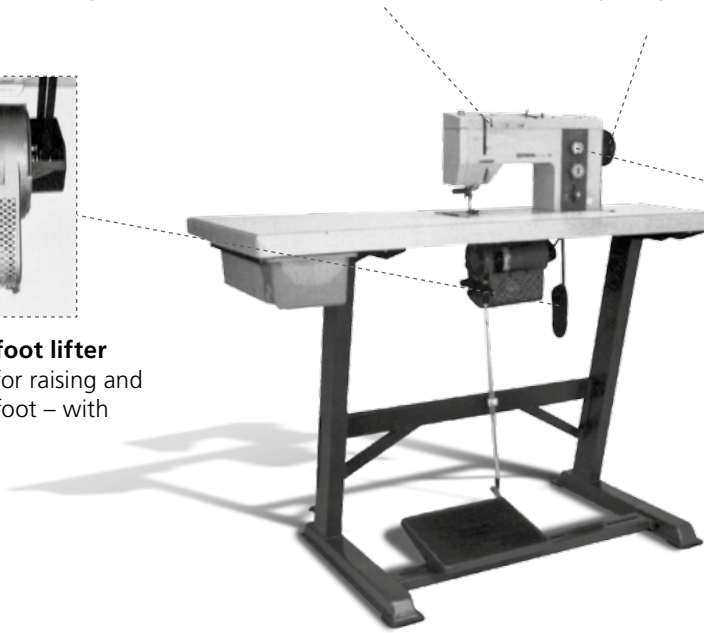

### Buttonholes

Turn the dial through 1 to 5 for precision-sewn buttonholes to the length of your choice on any fabric

#### TECHNICAL DATA

Base plate	373 x 178 mm
Arm space	210 x 104 mm
Hook	double rotation, transverse
Max. sewing speed	2000/rpm
Stitch length	forward and reverse up to 6 mm
Stitch width	up to 4.5 mm
Needle positions	5
Drop feed-dog	built-in
Darning device	built-in
Needle system	287 WH
Presser foot lift	7.5 mm
Bobbin winding	when idle or during sewing
Handwheel belt track Ø	approx. 80 mm
Gross/net weight	16.5/15.0 kg

#### STANDARD ACCESSORIES

- Universal feed-dog for all fabrics from sheer to thick.
- Presser feet:
  - Zipper foot
  - Blindstitch foot
  - Embroidery foot
  - Zig-zag foot
  - Darning foot
  - Buttonhole foot
- Handwheel release
- Feed-dog drop

#### SPECIAL ACCESSORIES

The 950 is available on request with any of the following options at extra cost:

- Industrial stand
- Halogen industrial sewing light
- Clutch motor kW 0.36 (1/2 PS)
- Foot control motor kW 0.18 (1/4 PS)
- Multiple spool holder
- External motor with foot control
- Spool holder extension combined with halogen sewing light